



NATIONAL MARINE ELECTRONICS ASSOCIATION



NMEA 2000®

Past, Present and Future

*Steve Spitzer, Technical Director, National Marine Electronics Association
Lee Luft, USCG Research and Development Center
David Morschhauser, Mystic Valley Communications, NMEA Technical Consultant*

RTCM MAY 2009 Annual Assembly Meeting and Conference
St. Pete Beach, Florida

NMEA 2000[®]

Past, Present and Future

RTCM 2009 Annual Conference
St. Petersburg, Florida

Steve Spitzer, Technical Director, National Marine Electronics Association

Contact Information

www.nmea.org

info@nmea.org

sspitzer@nmea.org

Purpose

This paper discusses the National Marine Electronic Association's (NMEA) marine networking interface standard, NMEA 2000[®]. It briefly illustrates the technical characteristics and architecture of the standard. It also provides a historical perspective, current highlights and a vision for future NMEA 2000 implementations.

Summary

NMEA 2000 has been created to meet a wide variety of needs. It is produced by the marine electronics industry as an Industry Open Standard. One important requirement is to provide for mission-critical data with multiple priorities. This requirement is addressed through proper application of multiple message priority levels of established by product certification. Message priorities are reflected in message identifier assignments, device classification codes, and application-dependent message priority bits. All certified NMEA 2000 devices must demonstrate the ability to adhere to NMEA 2000 requirements through automated software testing and validation. A product that passes certification testing will be capable of supporting mission-critical operations, even if that product in and of itself is not related to the mission-critical functions being conducted on the NMEA 2000 backbone. Data messages are transmitted as a series of data frames, each with robust error checking, confirmed frame delivery, and with deterministic transmission times.

There are 8 documents that comprise the NMEA 2000 Standard

- Main Document
- Appendix A Version (Application Layer)
- Appendix B Version (Database of Messages)
- Appendix C Version (Certification Criteria and Test Methods)
- Appendix D Version (Application Notes)
- Appendix E ISO 11783-3 Data Link Layer
- Appendix F ISO 11783-5 Network Management
- Appendix G ISO 11898 Controller Area Network

These can be purchased directly on the NMEA website. For updates, check www.nmea.org.

A single network cable replaces a myriad of cables used by today's methods of interconnection. The NMEA 2000 network accommodates navigation equipment, electrical power generation and distribution systems, engines and other machinery, piloting and steering systems, fire and other alarms, and controls. Data, commands, and status all share the same cable at speeds 26 times greater than the NMEA 0183 serial interface. NMEA 2000 is self-configuring; no setup is required, and no master controller is needed. Equipment may be added or removed without shutting down the network

Key to NMEA 2000 is an integrated circuit implementation of a network access protocol commonly known as CAN (Controller Area Network). First developed by Intel and Robert Bosch GmbH in the mid 1980's on the specification and development of integrated circuits for a device that would provide serial communications protocol to support distributed real-time control applications. CAN was developed to function in electrically noisy environments, to be robust, reliable, and have a predictable delivery time for any information being moved on the network.

The initial objective was to provide a robust solution for automotive applications that included high-speed networking as well as low-cost wire multiplexing. CAN was originally intended for real-time engine and transmission control, anti-skid braking systems, and to replace wiring body components. CAN is now a ubiquitous network protocol used throughout a myriad of industries, such as automotive, agricultural, robotic, factory automation, and others where a vigorous real-time deterministic protocol is required for absolute message delivery. The Society of Automotive Engineers (SAE) has developed a CAN-based network for use in trucks, buses and trailers. This SAE J1939 standard was later adopted by the International Organization for Standardization (ISO 11783) for use with agricultural machinery and implements. While these applications have differing types of data and commands to communicate, and differing requirements for the physical layer, the job of setting up and managing the data communication on the network is very similar to that needed for NMEA 2000 and maritime applications.

Integration of shipboard systems, sensing and control within systems, sharing of information, and collecting of data is occurring at an increasing rate on board vessels. These operations are happening in many parts of the vessel from the engine room, to the bridge, to administrative personnel, and even off of the ship to the owner's office by way of satellite communications links. To varying degrees, these applications exist on ships, coastal vessels, fishing vessels, and recreational boats and each of them require standardized data communications with varying capabilities.

Without a common, open network standard to provide data integration, equipment designers must provide multiple data inputs, which involving additional expense and wiring adding cost and weight, or use devices that "merge" data onto a single channel. Individual systems on a vessel, such as engine machinery or navigation systems, perform relatively dedicated functions, often have real-time requirements measured in milli-seconds, and need fewer connected nodes. These systems tend to be smaller and more self-contained when compared to other vessel more complex networks, and carry less data volume. Because NMEA 2000 network application integrates inexpensive sensors and actuators into larger systems, the cost per node may be far less than in other shipboard applications.

Some systems are important in running the ship, and may be used for payroll, inventory, and e-mail, they are not safety-critical systems nor do they have real-time requirements. They are built using commercial off-the-shelf Ethernet-based components. Decisions that affect the operation of the ship and involve the safety of the ship, the crew, the passengers, the cargo, and the environment are generally made on the bridge or other control centers as part of Integrated Bridge Systems. To efficiently make decisions and to carry them out requires access to information from many of the shipboard systems. These systems might include navigation, power generation, engines and machinery, fire alarm and control, etc. The unique maritime nature, security, availability, redundancy, and latency requirements of these connections may preclude the use of ready-made office-type LANs. International Electrotechnical Commission (IEC) TC 80 Working Group 6 is addressing these network requirements with New Work Proposal 61162-450.

Like Ethernet, CAN operates in the Carrier-Sense/Multiple Access Mode (CSMA). CAN listens on the bus. If the bus is not busy, data transmission may proceed. It is multiple access because if every device follows the rules that there can be many devices sharing the same bus. The difference between CAN and the Ethernet approach occurs when two devices simultaneously determine that the bus is not busy and both start to transmit. This leads to bus contention.

With Ethernet there is a data collision and both devices stop transmitting and try again later. Valuable time on the bus is lost during the collision and net bandwidth is reduced. CAN handles bus contention in a way that prevents loss of bus bandwidth. When bus contention occurs, CAN automatically arbitrates bus access on a bit-by-bit basis. The device with the highest priority prevails and continues to transmit data; the device with the lower priority waits. No data transmission time is lost.

In many modern day Ethernet networks, switches have replaced hubs so that every node may be able to transmit collision free. However, inexpensive off-the-shelf switches offer no priority enforcement. Further, in more expensive switches that offer prioritization, there is no standard. All switches introduce more single point of failures into the backbone and the more functional switches required to provide a framework for prioritization offer higher rates of failure due to great complexity. Real-time Ethernet networks with prioritization can get to be very expensive and complicated.

The following is from an article entitled: “Plug into Industrial Ethernet Protocols: *Industrial Ethernet protocols can be standard and unmodified, or modified to be industrially hardened. Perspectives from some protocol proponents clarify needs for various implementations.*”
by Mark T. Hoske, Control Engineering -- Control Engineering, 2/1/2009

“A side effect of Ethernet's increased use is that the word “Ethernet has become a generic term for a collection of “standards,” says Jeremy Bryant, Siemens Energy & Automation. “To some people, it even covers hardware like commercial off-the-shelf switches. The fact is there's no single 'standard' covering everything.” Bryant maintains that basic Ethernet “cannot meet the needs of automation. Therefore, all industrial Ethernet protocols are an 'enhancement' of the IEEE 802.3 standard. Put another way, all industrial Ethernet solutions (Profinet, EtherNet/IP, EtherCAT, etc.) are standards based (IEEE 802.3), but none can lay claim to be the industrial Ethernet standard because there is no recognized standards group for industrial networks.”

“The definition of “Ethernet” refers to the cabling system for transmitting data between connected devices. “On the ISO stack,” Bryant says, Ethernet is only the bottom two layers (layer 1 and 2) in the protocol stack. It's a bit like the RS-485 standard used by most fieldbuses—the key is what happens on the layers above. Without that, Ethernet is pretty dumb.”

“While a few industrial systems can pack data into standard Ethernet packets to take advantage of commercial Ethernet, , most industrial solutions require custom software at the OSI Layer 3 (and higher layers) and Media Access Control (MAC) hardware modifications to support multiple fieldbus and industrial Ethernet standards and real-time performance requirements.” Jason Chiang ,Senior Technical Manager, Altera Corp

“Although there have been efforts to apply commercial unmodified Ethernet to the plant or factory floor, the inherent non-deterministic nature of commercial Ethernet and non-ruggedized commercial media do not deliver the required level of high-speed reliable data exchange needed for today's manufacturing systems. Unmodified Ethernet allows data collisions to occur, detects them, and provides for retransmission, so determinism cannot be guaranteed without the use of additional hardware (Ethernet switches), which complicates network design,” Chuck Lukasik of CC-Link Partner Association says.

Below is a brief table summarizing some of the capabilities and differences between CAN and Ethernet protocols:

Controller Area Network (CAN) Protocol	Ethernet Protocol
CSMA – Carrier Sense Multiple Access with Non-Destructive Bit Wise Arbitration - A Collision less system that is deterministic – No lost Bandwidth when simultaneous multiple accesses occur.	CSMA – Carrier Sense Multiple Access with Collision resolution being non deterministic – Bandwidth is lost when collisions occur.
All messages are broadcast	Guaranteed point-to-point delivery - you just don't know when

Controller Area Network (CAN) Protocol	Ethernet Protocol
Bandwidth is constrained by the need for each node to sample the bus at the same time - 62.5Kbit to 1Mbit	Large bandwidth -10Mbit and up
Cable length constrained by the need for each node to sample the bus at the same time – 1,100 meters at 62.5Kbit to 25 meters at 1Mbit	Cable length - 100 meters
Multiple error checks on all transmitted messages - CRC, bit stuffing, and all nodes participate in error checking of each transmitted message	
Automatically determines when its node is having repeated errors and will automatically take a node off-line to protect the rest of the network.	
Guaranteed correct message transmission.	

The marine electronics industry utilized CAN as the basis to develop the bi-directional multi-transmitter/multi-receiver instrument network to interconnect marine electronic devices, NMEA 2000. In collaboration with IEC TC 80 Working Group 6, the NMEA 2000 Standards Committee and Working Group 6 jointly developed IEC 61162-3 which references the National Marine Electronics Association's NMEA 2000 with specific rules for SOLAS Class Vessels.

The NMEA 2000 network allows multiple electronic devices to be connected together on a common channel for the purpose of easily sharing information. Because it is a network, and because multiple devices can transmit data, a more comprehensive set of rules is required that dictate the behavior of the members of the network. CAN automatically provides some of these rules – mostly for control of access to the network, packet transmission, and error detection.

The elements necessary to define a NMEA 2000 network to be used in multiple applications by different designers and manufacturers are:

- Definitions for the use of the bit sequence transmitted by CAN to send data
- Uniform ways of identifying devices on the network and assigning addresses for each node
- Common rules for requesting data, sending commands and acknowledgements, and for transmitting blocks of data on the network
- Descriptions and definitions of a standard set of data messages that are to be sent on the network, plus a provision for manufacturers to send proprietary messages on the network

Equipment designed to this standard will have the ability to share data, including commands and status, with other compatible equipment over a single signaling channel.

The NMEA 2000 Standard defines all of the pertinent layers of the International Standards Organization Open Systems Interconnect (ISO/OSI) model, from the Physical Layer to the Application Layer, necessary to implement the required NMEA 2000 network functions. The NMEA 2000 Standards Committee commonly references other international standards within NMEA 2000 Standard to assure commonality within and outside of the marine industry.

The components of an NMEA 2000 network are:

- Physical Layer. Fully defined by the standard, including signaling voltages, cables, and connectors.
- Data Link Layer. Defined by ISO 11783-3 with additional requirements specified by the standard.
- Network Layer. To be defined in future versions of the standard.
- Network Management. Defined by ISO 11783-5 with additional requirements specified by the standard.

- Application Layer. Fully defined by the standard and includes a provision for manufacturer's proprietary messages.

Network Characteristic Summary	
Network architecture	<ul style="list-style-type: none"> • Bus (parallel) wiring configuration using 4-conductor twisted-pair wire to carry power to operate the interface and data signals. • Linear network with end terminations and multiple short-length drop cables connecting the backbone cable to individual nodes
Network operation	<ul style="list-style-type: none"> • Network access: Carrier Sense/Multiple Access/Collision Arbitration using CAN (Controller Area Network) • Multi-master network operation (no central control node) • Self-configuring • Special network tools, desirable for diagnostic purposes, are not necessary for operation
Network size	<ul style="list-style-type: none"> • Physical nodes: Up to 50 connections • Functional nodes: Up to 254 network addresses • Length: Up to 200 meters (at 250kbits/second bit rate)

The Physical Layer:

This layer defines the electrical and mechanical aspects of the physical link between network connections, and references characteristics of the CAN devices and network interfaces to be used in NMEA 2000.

The electrical characteristics of the physical layer are dictated by the following:

- Media access uses CAN as defined by ISO 11898, *Road Vehicles - Interchange of Digital Information, Controller Area Network (CAN) for High-speed Communication*
- CAN utilizes dominant/recessive bit transmission.
- Time delays and network loading limit bit rate and network length.
- Differential signaling improves noise immunity.
- Network single-point common signal reference controls ground voltage levels and reduces RFI.

The marine shipboard environment can be electrically noisy. With interference from alternators, motors and relays, wires passing through this environment will pick up this noise and carry it to the input of the interface circuit. To reduce the effects of this kind of interference, NMEA 2000 specifies differential transmitters and receivers.

Differential signaling still requires that interface circuits are powered from a signal-reference common to all nodes on the network. A single-point common reference is specified in order to avoid radio-interference caused by ground loops and to maintain control of ground-voltage levels between nodes. The common signal point reference is accomplished by powering the signal transceivers in each device solely from the backbone and isolating transceiver power from any other power sources or electrical connections to the device. This fundamental characteristic of NMEA 2000 is different from most other networks and makes it possible to connect a wide variety of high-impedance lower power equipment over long distances.

In all cases the power and common for the interface circuits must not connect to other power or ground in a network device. This isolation may be achieved in a number of ways. One is by use of isolation circuits (e.g., opto-isolators) within the device, either at the interface or at specific places where the equipment connects to other devices. In addition, AC and DC isolation is required between all of the terminals at the interface connector and any other connection point on the device, with the network cables disconnected, and any other electrical interface or connection on the device.

The following block diagram illustrates a typical implementation for a 4-wire network with an isolated interface; the shield conductor is not shown. Network power is provided on the NET-S and NET-C wires, and the NET-H and NET-L wires carry the differential signal. Each end of the signal pair is terminated to prevent reflections along the backbone. Ground isolation, illustrated with opto-isolators, is shown between the transceiver circuits connected to the network and the remaining device electronics.

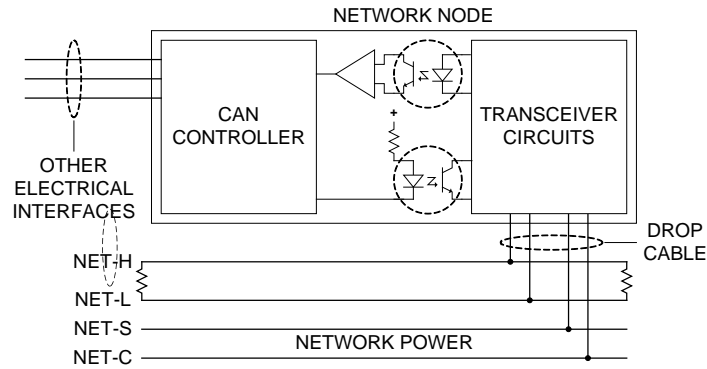

Device Physical Layer Block Diagram

The opto-isolators create very high impedance between other electrical interfaces to the device and the NMEA 2000 network interface. Other electrical interfaces include any analog or digital inputs or outputs, as well as power connections to supply the CAN controller and any other circuitry within the device.

NMEA 2000 implementations must meet the Durability and Resistance to Environmental Conditions and meet the Unwanted Electromagnetic Emissions and the Immunity to Electromagnetic Environment conditions of IEC 60945.

The interface circuits must operate over the range of 9.0 to 16.0 Volts DC. The voltage for the interface can either be supplied from the network backbone cable or supplied by a dedicated twisted-pair power cable connected only between a single node and the network power source (the vessel's battery or one regulated power supply). The amount of current delivered by the network cable is limited.

The maximum length of the network is controlled by the CAN requirement that all nodes on the network sample the same bit at the same time. Theoretically this translates to the following:

- 1,000 kbits/second - 25 meters
- 500 kbits/second - 75 meters
- 250 kbits/second - 200 meters – NMEA 2000 Standard
- 125 kbits/second - 500 meters
- 62.5 kbits/second - 1100 meters

Problems can be envisioned however, if nodes operating at different bit rates are connected to a network segment.

Cables and Connectors

Two types of cable are specified heavy and light (see below). The NMEA Standards Committee searched for a specification that would more than meet the rugged marine requirement for durability and safety. The Open Devicenet Vendor Association's physical layer cable and connector specification was chosen since it was a proven and robust specification. The requirements for the cable and connector shall meet the Open Device Net Association (ODVA) Volume Three Edition 1.1 as referenced in the NMEA 2000 Standard. The ODVA Specification is a standard for cables and connectors for automotive, robotic and other terribly rough environments, includes an IP67 rating, standardized pin layout, and passes all of the required tests detailed in the NMEA 2000 Standard. Cable specified for the network must meet both the

characteristic impedance and propagation delay requirements for use as a transmission line, and also the wire-size needs of the DC power distribution function of the cable.

	Light Cable(Micro)	Heavy Cable (Mini)
Signal Wire Gauge	24 AWG	18 AWG
Power Wire Gauge	22 AWG	16 AWG
Power Wire Resistance	5.7 ohms per 100 meters	1.6 ohms per 100 meters
Maximum Current	3 amps	8 amps

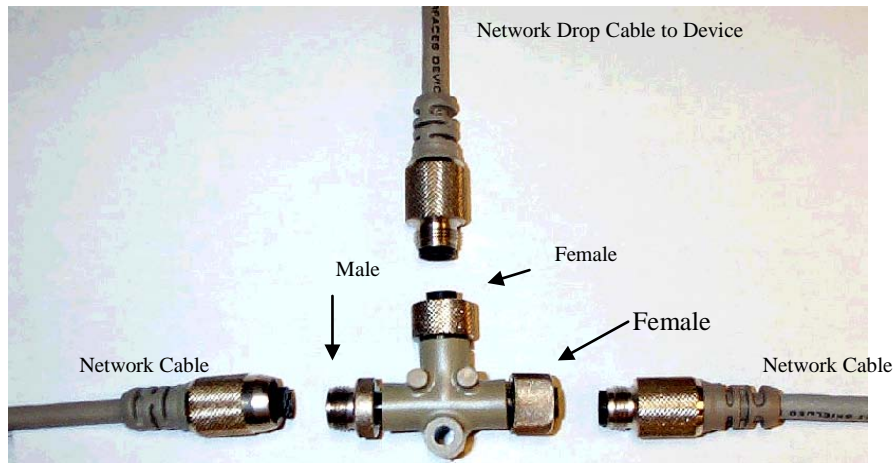

NMEA 2000 Standard Cable and Connector
Photo courtesy of Molex Corporation

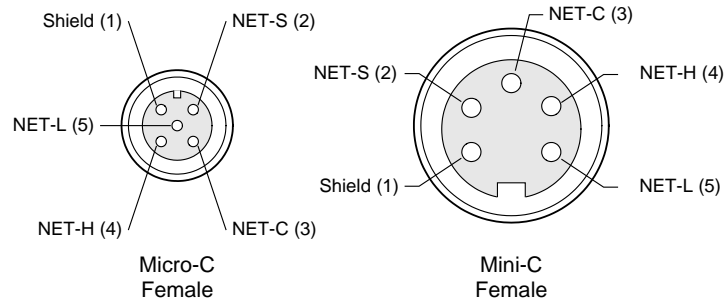

Two methods are provided for connecting to the network backbone cable: barrier strips or a standard cable and connector. These connections are used for connecting segments of backbone cable together, for connecting terminations at the two ends of the cable, for connecting the network power source, and for connecting nodes.

Barrier strips are only recommended when the connections are made in a protected location, or when they are installed in a weatherproof enclosure, thus meeting the requirements for Resistance to Environmental Conditions for exposed equipment in IEC 60945. Barrier strips positions must be either numbered or color-coded in accordance with the definitions in the standard.

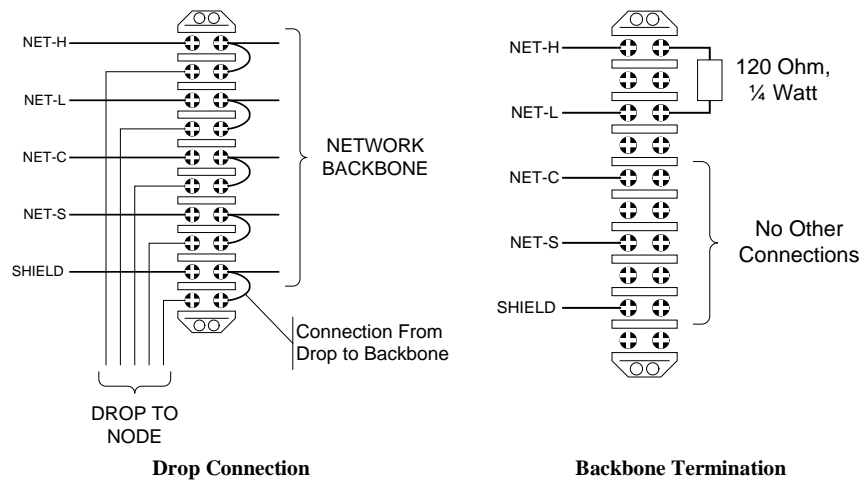

Barrier Strip Configuration

General Topology

The general topology of NMEA 2000 is known as “Trunk and Drop” or “Backbone and Drop” and is shown below. The NMEA 2000 backbone is connected in a continuous linear form without branches, forks, or loops. Each device is connected to the backbone via individual taps and drop cables. NMEA 2000 is designed to have two termination resistors to reduce line reflections, one at each end of the linear network cable. To minimize network disturbance when electronic devices are disconnected from the network, the termination resistors must be on the network backbone cable itself and not internal to a connected device or on a drop cable.

Besides the greater amount of control and integration provided, NMEA 2000® replaces with a single cable all of the wiring of up to 50 NMEA 0183 interconnections and can handle the data content of between 50 and 100 NMEA 0183 data streams.

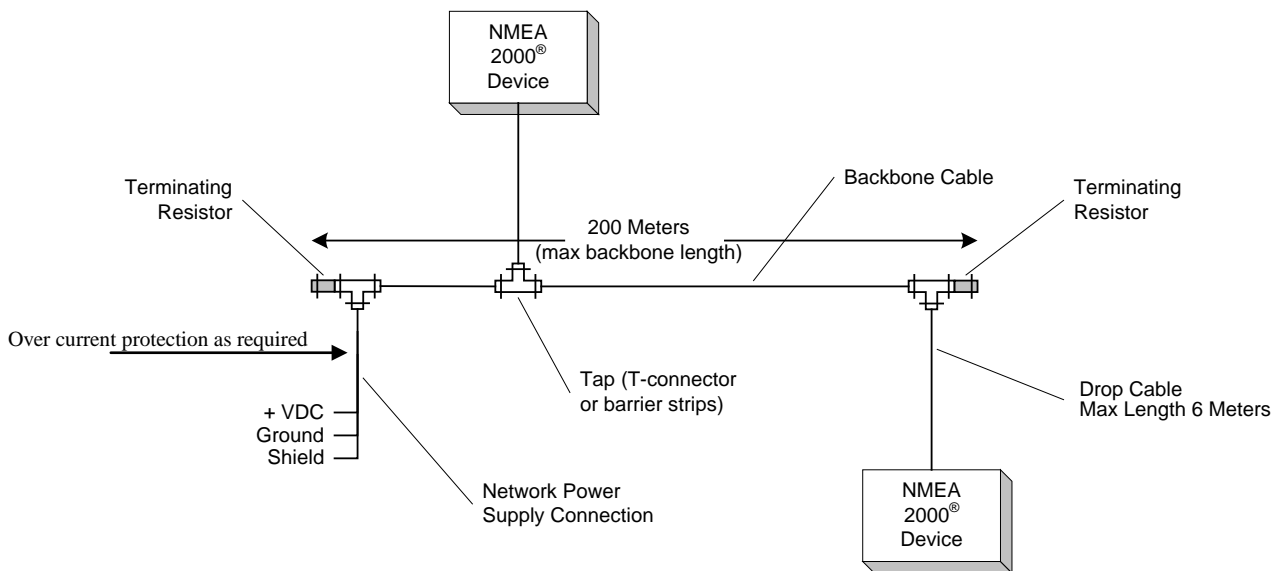

Simplistic NMEA 2000 Bus Topology

Network Power

NMEA 2000 interface circuit drivers are required to remain operational when supplied a voltage in the range from 9 to 16 volts DC. The power for the drivers is provided from the NET-S and NET-C pair on the backbone. The wide operational voltage range affords a variety of options for supplying backbone power, including either direct connection of a vessel's 12-volt system or isolated power supplies that draw power from higher voltage DC systems or AC systems.

NMEA 2000 Certified devices list the power drawn from the backbone using a Load Equivalence Number (LEN) for use in planning and installation. The LEN represents the integer multiples of 50mA drawn by the device. For example, a device that draws 100mA would specify a LEN of 2, and a device that draws 101mA would specify a LEN of 3. The maximum power that a device may draw from the backbone is 1.0 Amp, or 20 LEN.

If power to supply the remaining needs of a device is likely to exceed 1.0 amp, that power must be provided using a separate power supply connection. Devices with no electrical connections other than the NMEA 2000 interface, but which draw more than 1.0 amp (20 LEN), may be designed to connect to the network power source using a separately routed, dedicated power lead. Details on how to connect such devices are discussed in detail in the NMEA Installation Standards.

NMEA 2000® backbone power is provided using one of the following means:

- Direct Battery – The vessel's 12-volt battery may be connected via the vessel's DC supply system to the backbone power connections. Only one connection is provided, which may be located at either end of the backbone or at any point along the backbone.
- Isolated Power Supply – One or more isolated 15-volt power supplies may be connected directly to backbone power insertion points. Multiple power supplies may be used to create multiple power insertion points for redundancy or to accommodate load.

Battery connections and isolated power supply connections are never combined on the same NMEA 2000® network

Multiple power supplies may also be connected to any single power insertion point in order to provide redundant sources for the associated backbone power leg, in accordance with requirements for diode protection and over-current protection as in the NMEA 2000 Standard and the NMEA Installation Standard.

One common method to overcome voltage drops on large backbone networks is to use two legs from a single power insertion point extending in opposite directions. These types of installation provide greater flexibility while still conforming to meet all of the requirements. Isolated power supplies "approved for the use" with NMEA 2000 may be used. Each NMEA 2000® backbone power leg shall be provided with over-current protection in accordance the proper and appropriate domestic and international standards for power protection.

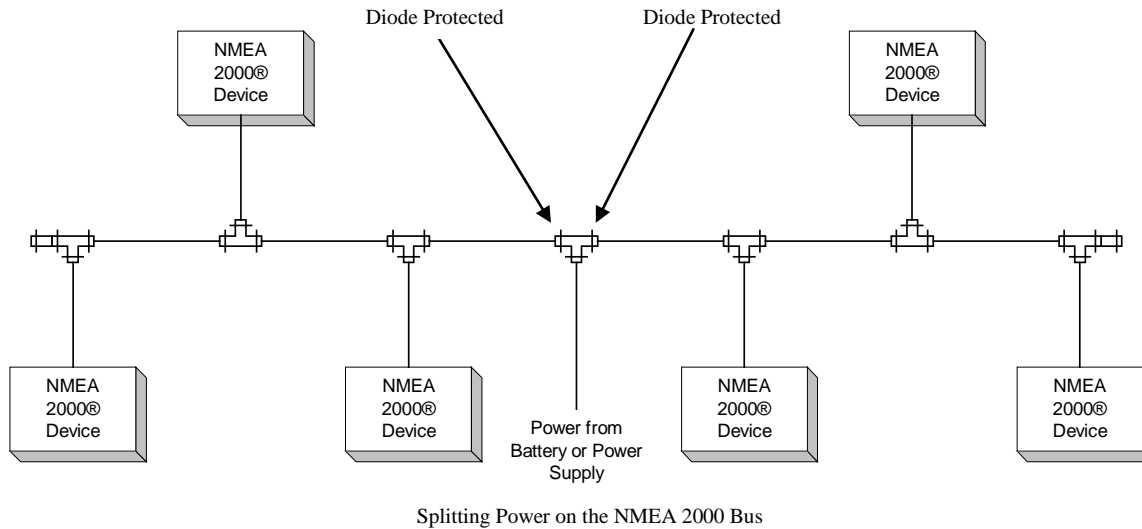

Data Link Layer

NMEA 2000 references the data link layer of the international standard ISO 11783-3 which is virtually identical to the SAE data link layer SAE J1939-21. This international standard is to be used in its entirety, but in addition the NMEA 2000 data link layer provides enhanced features and functionality. These additions better support the type and format of data contained in NMEA 2000, and support the unique way that electronic devices are designed, installed, and operate on board vessels.

Like the physical layer, some of the requirements of the data link layer are dictated by the choice of CAN for media access.

Much more capable than a universal asynchronous receiver/transmitter (UART), the functions of CAN are to:

- Generate the serial bit-stream that is to be transmitted on the network.
- Gain access to the network when the equipment has data to send. It does this by sensing when the network is not busy. If there is a collision with another device trying to put data on the network CAN automatically compares each transmitted bit and arbitrates access on a bit-by-bit basis with Dominant bits winning. With this method there is no wasted network time due to collisions.
- Perform error checking and automatic retransmission of bad messages. CAN also automatically determines when its node is have repeated errors and will automatically take a node off-line to protect the rest of the network.

The serial data frame used by CAN has a 29-bit identification field and from zero to eight data bytes. In addition the frame contains start of frame and end of frame bits, reserved bits, frame control bits, a 15-bit CRC error detection field, and acknowledgement bits.

Data messages are transmitted as a series of data frames, each with robust error checking and confirmed frame delivery. Data frames contain, in addition to control and error-checking bits, an 8-byte data field and the 29-bit identification field that sets message priority and identifies the data message, the source, and the destination.

NMEA 2000 adopts the J1939 / ISO 11783 use of the identification field. The highest-order bits, the first ones transmitted, are network access priority bits. Each of the bits in the identification field are used during the arbitration process when there is a network access conflict, but these bits come into play first.

Network Management

Similar to the data link layer, the procedures used in the management of the NMEA 2000 network are aligned with international standard ISO 11783-5 that is based on SAE J1939-81. Network management is responsible for:

- The claiming and assignment of addresses on the network.
- The identification of the devices connected to the network.
- Network initialization at power-on.

It is a requirement that each device connected to the network have an address. There are 252 available addresses in the one-byte address field; addresses 252 through 255 are reserved.

All NMEA 2000 compliant devices must be self-configurable and capable of claiming addresses according to the ISO 11783-5 protocol.

Part of the address claim procedure, the part that allows one device to take the address of another, involves the use of the device NAME. NAME is the contents of the data field of the Address Claim message and must be unique for every device on the network. It consists of sub-fields containing codes for device function, instance numbers for multiple devices of the same type, manufacturer code, and a unique number assigned by the manufacturer. The latter, like a serial number, must be unique for every device of the same type produced by a manufacturer. During the address claim process, claims on the same address are won by the device whose name has priority.

The CAN identifier of every frame transmitted on the NMEA 2000 backbone must be unique to ensure that arbitration is completed at the end of the address claim process with only a single winning device. Uniqueness is accomplished by including within the CAN identifier a unique source address for each device connected to the backbone. Assignment of addresses from within the available address space is accomplished using an automatic address claim process so that devices connected to the backbone can immediately begin transmitting without the need for a central controller. The address claim process consists of a specifically constructed sequence of steps that are followed by each device as it connects to the backbone. Conflicts arise when more than one device tries to claim the same address. These conflicts are arbitrated based on the numeric value of the 8-byte data field (NAME) within the Address Claim parameter group.

First, the device selects a default address based on the manufacturer's software and attempts to claim that address by broadcasting an Address Claim parameter group along with a unique identification number that comprises the manufacturer's product code, the device's assigned function and class code, and a unique number assigned by the manufacturer to ensure that no two devices from the same manufacturer will have the same identification number. Optionally and under certain conditions, the device may broadcast a request for all existing devices to transmit their Address Claim parameter group in order to logically select an available address based on how the backbone is already populated.

Second, the connecting device listens for any Address Claim parameter groups that would indicate that there is a device with a higher priority on the backbone that already has claimed the address the connecting device has chosen. If no conflicting Address Claim parameter group is received within 250mS, the device may conclude that the address claim has been successful and begin to transmit application messages on the backbone.

If the device receives a conflicting Address Claim message, it confirms that the device transmitting the conflicting Address Claim parameter group has a higher priority by comparing the NAME identification

number received along with the address claim and comparing it with its own NAME identification number. The device with the lower NAME identification number receives priority. Having received notification that a higher priority device has already claimed the address desired, the connecting device chooses a new address and begins the process again with that new address. This process is repeated until an address is successfully claimed or until all addresses have been tried. Every device connected to the backbone that has successfully claimed an address is permitted to transmit parameter groups in accordance with its functional design.

In addition to NAME, NMEA 2000 provides messages containing additional information about the device. Parameters such as model number, product version, software version, NMEA 2000 version supported, and installation comments are available in separate messages. The more powerful NMEA 2000 request message defined in the data link layer may be used to search fields of these messages and the NAME message for the purpose of building a map of the network to identify the number and types of devices connected. Every certified NMEA 2000 device has a pre-assigned Device Class and Function Code as specified in the NMEA 2000 Standard.

The Application Layer

The Application layer defines the approved messages; both network management and data messages that are transmitted on the NMEA 2000 network.

Messages transmitted on the network are organized into parameter groups that are identified by a parameter group number (PGN) that appears in the CAN identifier field as either an 8-bit or 16-bit value depending on whether the parameter group is designed as an addressed or a broadcast message. Depending on the amount of data, the parameter group may require one or more CAN frames to transmit the data.

The mechanism for exchanging data between devices connected to the NMEA 2000 backbone is the parameter group. A parameter group is a specific data record containing one or more data fields, or parameters, related to the transmitting device or to the vessel. Parameter groups are usually periodic and represent the current parameter values. Receipt of multiple repetitions of the same parameter group from the same device generally denotes a time value sequence of data values and may be used for display or control purposes.

Parameter groups are defined in the NMEA 2000 Standard, Appendix B, and are identified by a Parameter Group Number (PGN) that appears in the CAN identifier field along with other information related to the priority, source, and destination of the transmitted parameter group. Since a CAN data frame contains only 8 data bytes, a parameter group may require one or more CAN frames to transmit all parameters for that parameter group.

A parameter group definition includes the following descriptive information:

- **Frame Count** – Whether the parameter group can be contained within a single 8-byte data frame or must be divided into several frames. Multiple frame parameter groups are sent using the Fast Packet protocol by default.
- **Priority** – The default priority of the frame within the system. Parameter groups with higher priority will take precedence over lower-priority parameter groups, regardless of PGN or source address.
- **Periodic Rate** – If the parameter group is to be sent periodically, the default rate that the parameter group will be queued for transmission.
- **Destination** – Whether the parameter group can be sent to a particular address, or if it will always be broadcast to all devices.
- **Query Support** – The fields within the parameter group that can be queried, whether query support is optional, and what acknowledgment requirements may be for successful and unsuccessful queries.

- Field Definitions – Each field within a parameter group is defined by name and using the following linked references to identify the underlying data format:

Each data field has a description defined by a data dictionary entry. Each data dictionary item is of a defined format, usually representing the physical parameter being defined. Physical parameters are finite, so there are fewer data format entries than data dictionary entries. The data formats are based on the International System of Units (SI). Each data format is represented by a single standard data type, such as Character, Integer, or Unsigned Integer.

An example of a Parameter Group definition is illustrated below:

ISO Acknowledgment		PGN: 059392	
This message is provided by ISO 11783 for a handshake mechanism between transmitting and receiving devices. This message is the possible response to acknowledge the reception of a "normal broadcast" message or the response to a specific command to indicate compliance or failure. The application layer is responsible for determining when this message is desired, outside of network management requirements specified by this standard (e.g. response to ISO Request message). This message will always be sent with a destination address of 255.			
Single Frame:	Yes	Priority Default:	6
Default Update Rate:	NA milliseconds	Frequency:	NA cycles per second
Destination:	Address	Query Support:	ACK Rqmnts:
Field #	Field Name	Byte Field Size:	Bit Field Size:
1	Control Byte 0x00 = Positive Acknowledgment; 0x01 = Negative Acknowledgment; 0x02 = PGN supported but access denied; 0x03 to 0xFF = Reserved		8
2	Group Function Value Group Function of PGN being acknowledged. This field identifies for a device the specific group function of a PGN being acknowledged or declined. This field is not used if the PGN being acknowledged or declined is not a group function PGN.		8
3	Reserved Bits Variable number of reserved bits, all set to logic "1"		rsv 24
4	PGN of Requested Information 24-bit Parameter Group Number (PGN) expressed in binary, LSB is transmitted first		24

NMEA 2000 Product Certification

The NMEA 2000 Certification program was conceived to ensure that NMEA 2000 products meet the necessary minimum requirements to interoperate properly. The certification program is implemented as a self-certification process using mandated test equipment with formal validation by the NMEA. The mandated test equipment ensures that required testing is performed in a uniform manner throughout the industry.

The National Marine Electronics Association provides a self-certification tool to aid manufacturers in testing their product(s) during development and prior to final release. A key element of the NMEA 2000 Certification program is the NMEA 2000 Certification Tool. The certification tool consists of a CAN interface for a personal computer and software that implements the test procedures identified in NMEA 2000 Standard, Appendix C.

The NMEA requires that any device providing a NMEA 2000 interface must pass the self-certification test before that product may claim that it offers NMEA 2000. This is to ensure that all NMEA 2000 based devices implement the network protocols properly. This testing also ensures that the automatic self-configuring capabilities defined by the NMEA 2000 standard are properly implemented and do not for any reason, cause or generate problems for other equipment on the network. The testing is designed to expose any flaws or weaknesses in the NMEA 2000 protocol implementation and ensure that all devices from all manufacturers behave in a known and predictable manner on the network. This testing does not validate the data or measurements provided by a device, only how it interacts on the network.

To obtain product certification, a manufacturer connects their device to the certification tool and executes all the tests. Some tests require physical measurements (such as voltage levels or ground isolation) and are referred to as manual tests. The software prompts the user for the information needed for each manual test and stores the information in a database. At any time, the user can instruct the software to conduct the many network protocol tests; these are referred to as automated tests. The results of these tests are added to the test database on the user's PC. The user can observe the results of each test on-screen, and is provided with an ASCII file of the complete test results. In order to receive certification, the encrypted test data base file must be sent to NMEA for validation. Only after a device has passed all the tests successfully, and NMEA has validated the results, can a device be NMEA 2000 certified. Proper behavior on the network ensures that devices will be able to safely and accurately communicate and share data with all other certified products.

Past

The National Marine Electronics Association (NMEA) completed and released the NMEA 2000 Standard for Serial-Data Networking of Marine Electronic Devices during October 2001. The development of this standard began with the NMEA 2000 Standards Committee in 1994. The Standards Committee from its beginning has been comprised of a multi-national collaboration. After five years of development, the NMEA 2000 standard was put through an eighteen-month beta test.

NMEA 2000 Standards Committee Then and Now

1994 NMEA 2000 Standards Committee Members	1999 Beta Group (18 Months of Testing)	2009 NMEA 2000 Standards Committee Members
Ashtec/Magellan	Furuno USA	Active Research Limited
Brookes Gatehouse	JRC	Airmar Technologies
ComNav Marine	Litton Marine	Azimut
Datamarine	Navionics	Blue Water Data
Furuno USA	Northstar	BRP/Evinrude
Furuno Electric Company	Raytheon Marine	BEP Marine
JRC	Simrad	Capi2
Kansas State University	Teleflex	Colemo Systems
Kvaser AB	Trimble	CPAC Systems
MacKay Communications	Wood Freeman	CWF Hamilton Jet
Morse Control	Kvaser AB	Deif
Navionics	Vector Can Tech	Digital Switching Systems
Network Intergration		Deutsch Connectors
NMEA		Emmi Network
Nobeltec		Faria Instruments
Oklahoma State University		Fireboy Xintex
Raytheon Marine		Flir
Raytheon Anshutz		Floscan
Silva Productions AB		Furuno USA
Sperry Marine		FW Murphy
Teleflex Electrical		Garmin
Trimble Navigation		Glendinning Products
USCG R& D Center		Honda Motor Company
US Navy – Surface Targets		Hummingbird
Vector Can Tech		Imor Engineering
		John Deere
		JRC
		Kohler Power Systems
		Krill Systems
		Kvaser AB
		Magnum Power
		Mareton
		Mastervolt

1994 NMEA 2000 Standards Committee Members	1999 Beta Group (18 Months of Testing)	2009 NMEA 2000 Standards Committee Members
		Maxsea
		Medallion Instruments
		Molex
		Moritz Aerospace
		Mystic Valley Communications
		Nautical Systems
		Navico
		NMEA
		Offshore Systems
		Oklahoma State
		Paneltronics
		Phoenix Contact
		Phoenix International
		Pulse Electronics
		Raymarine
		Sailormade Brazil
		Satloc/NAITF
		Silva
		Sperry
		Standard Horizon
		Suzuki
		TC80 WG 6 (IEC)
		TechMarine
		USCG R&D Center
		Vector Can Tech
		VEI Systems
		Victron Energy
		Volva Penta
		Westerbeke
		Yamaha Motor
		YanMar
		ZF Marine

The four photographs below are provided courtesy of Teleflex Morse. The vessel is a 25ft Cherokee with twin inboard engines and electronic shift and throttle controls. There are no mechanical controls between the helm and the engines.

This vessel has been operating with this NMEA 2000 based equipment suite since April 18th 2001, supporting local law enforcement activities.

The upper left photograph depicts the helm of the boat. All instrumentation (Teleflex i5500 Displays for engine monitoring) and engine shift and throttle controls are connected to the NMEA 2000 network.

The upper right picture shows the twin 8.1 liter GM Crusaders Engines controlled by the network.

The lower left picture shows the two Teleflex i6000 Engine Control units. Each Engine Control Unit is connected to the NMEA 2000 network via a drop cable and a “T” connector. One end of the NMEA 2000 network is terminated in this picture. The other terminated end of the network is not shown.

The lower right picture shows the two Teleflex i8105 Engine Interface Units along side the Engine Control Units. The drop cables for the Engine Interface units connect to the same NMEA 2000 network via “T” connectors. These drop cable network connections are not visible in this picture.



From its beginnings, NMEA 2000 was designed to begin a paradigm shift in the marine electronics industry. Even though, the marine electronic industry created, tested and adopted NMEA 2000, the paradigm was sluggish in its acceptance. Today 10 years after the successful beta testing, NMEA 2000 has found its way in the marketplace. It is being strongly demanded by the consumer in the high volume recreational market. NMEA 2000 will reside in harmony with other protocols within the high seas market as the knowledge base becomes more familiar with the benefits of NMEA 2000 and CAN.

Present

In the beginning, there were twenty-five organizations involved, today there are sixty-six organizations on the NMEA 2000 Standard Committee e-mail reflector list that are deeply involved and committed. This does not include 100s of companies that have purchased the standard to prepare products for the future. NMEA 2000 more than ever is truly a Multi-National Committee. Companies from Europe, Asia, Australia/New Zealand and the U.S. collaborate and strive for consensus when new technologies emerge that warrants NMEA 2000. All categories of electronics are represented; from engines, to navigation to power to boat sensor such as fuel, depth and wind.

NMEA 2000 Standards Committee

The NMEA 2000 Standards Committee has evolved to a much more formal group. There are standing committees and working groups. The Committee has formulated processes and strict technical rules for

on-going development of NMEA 2000. It collaborates with other domestic and international associations such as ABYC, IEC, ISO, NMMA, RTCM and SAE.

Today, the structure of the Committee looks like this:



NMEA 2000 Messages (PGNs)

As noted above, messages in NMEA 2000 are defined as Parameter Group Numbers (PGN). The Parameter Group list consistently grows as companies want to add new capabilities to their products and to the standard. Currently, there are 105 PGNs. The marine industry has found that creating a PGN involves a greater amount of technical expertise than creating a NMEA 0183 sentence. As you can see above, there is a PGN Standing Subcommittee that created the process for applying for new PGNs and they also review the technical aspects of the PGN before it heads to the Committee.

For the NMEA 0183 purist, there is no one to one relationship between a NMEA 0183 sentence and a NMEA 2000 PGN. Further discoveries have found that the margin of error for the interpretation an NMEA 2000 PGN compared to a NMEA 0183 sentence is marginalized by the structure of the NMEA 2000 PGN. The NMEA 2000 PGN is created in binary form while NMEA 0183 is in ASCII. The structure of a PGN definition is defined in detail within the NMEA 2000 Appendix A document. PGNs are updated on the NMEA website; www.nmea.org. See Agendum I of this document.

As noted, a parameter group definition may describe a data record that consists of more data than can be contained within a single CAN frame. NMEA 2000 transfer methods include transmitting single-frame parameter groups and two methods of transmitting multi-frame parameter groups. These transfer methods are compared below:

Single Frame	ISO 11783 Multi-Packet	NMEA 2000 Fast Packet
8 bytes of data	Can convey up to 1,785 bytes of data	Limited to 223 bytes of data
Destination only as defined by PGN	Can be used to send any broadcast PGN (greater than 8 bytes) to a specific device	Destination only as defined by PGN
No handshaking	Contains “handshaking” (i.e., smart transfer methods)	No handshaking
No Transfer Protocol Delays	Takes longer to send the same amount of data as Fast Packet	Takes less time to send up to 223 bytes; no Transfer Protocol Delays
Implemented by all industries	Implemented by all industries	NMEA 2000 and adopted by ISO for GNSS Con/Ag applications

The Multi-Packet protocol specified in ISO 11783-3 provides for the transmission of multi-frame parameter groups up to 1,785 bytes. The protocol encapsulates the parameter group in a transport “envelope” and sends it to either a global or specific address. Flow control is provided so that when sending data to a specific address, the receiving device can start, stop, and control the data flow in accordance with the receiving device’s available resources. When parameter groups are sent this way, the identity of the parameter group is lost until the “envelope” is opened up to find out what data is being received.

The Fast Packet protocol defined in NMEA 2000 provides a means to stream up to 223 bytes of data, with the advantage that each frame retains the parameter group identity and priority. The first frame transmitted uses 2 bytes to identify sequential Fast Packet parameter groups and sequential frames within a single parameter group transmission. The first byte contains a sequence counter to distinguish consecutive transmission of the same parameter groups and a frame counter set to frame zero. The second byte in the first frame identifies the total size of the parameter group to follow. Successive frames use just single data byte for the sequence counter and the frame counter. Because many of the NMEA 2000 parameter groups exceed 8 bytes but do not require the 1,785-byte capacity of multi-packet, the default method of transmitting multi-frame parameter groups in NMEA 2000 is using the Fast Packet protocol.

Regardless of which protocol is used, multi-frame parameter groups are sent on a frame-by-frame basis and may be interspersed with other higher priority parameter groups using either protocol, or even single-frame parameter groups. Each device is responsible for reassembling the parameter group once all the frames for the parameter group are transmitted.

Updating Software and Firmware on the NMEA 2000 Network

Today, many companies have the capabilities to update their software and firmware via the NMEA 2000 network. The means are available with the NMEA 2000 protocol. Most companies today are using a proprietary PGN for their respective updates. Some companies today have gone past the experimental stages and are implementing updates via the web and or handheld devices remotely.

In a real life experimental situation at an NMEA Plugfest, a NMEA 2000 bus was simulated to 98% bus load while at the same time a company performed a reprogramming (uploaded and verified over the bus) of their software. While this was all happening, the NMEA 2000 Committee was able to observe (via NMEA 2000 diagnostic tools) that the highest priority engine PGNs were the first messages to transmit and arrive on the bus. Lastly, the software updates were successful.

- Rich Gauer, President of Maretron, attested to the following:
“Maretron has been loading updated firmware/software into its products over the NMEA 2000 network since 2004. We have done tens of thousands of updates all over of the world through our dealer network using a PC and USB/NMEA 2000 Certified gateway (USB100). The dealers simply jumps on the internet and downloads all the latest versions of firmware/software from our web page, then goes to the boat and plugs the USB100 onto the network, starts the program which identifies which devices need updating automatically, and when the user is ready, the update takes place on a live operating NMEA 2000 network.”

NMEA 2000 Certification

Product certification is granted for two classes and at two levels within those classes. Class 1 devices generally have a single NMEA 2000 interface that is used for all communication with other devices. Class 2 devices have dual-redundant NMEA 2000 interfaces intended to be connected to redundant NMEA 2000 backbones, where parameter groups are intended to be transmitted in parallel on both interfaces.

Only products that have been certified by NMEA may use the NMEA 2000 logo:



Additional requirements are placed on Class 2 devices to ensure correct identification of identical parameter groups when received by another Class 2 device connected to the same two NMEA 2000 backbones. Note that bridges may be certified for either class; however, a bridge with two NMEA 2000 backbone connections would usually be a Class 1 device because parameter groups are transmitted on each backbone independent of the other.

Two levels, Level A and Level B, have been established in order to accommodate a wide range of devices with varying processing resources. In particular, Level B was established to accommodate simple devices with minimal processing power and memory. One main impediment to low-power, minimal-memory implementations was implementing the ISO Transport Protocol, which depends on a large amount of memory for buffering. Level B was further simplified by omitting requirements to implement complex parameter groups with multiple functions that were only apparent after examining the data contained within the frame. With these reductions in complexity, Level B devices are now possible using simple mailbox-style interrupt mechanisms used in less-powerful systems.

The table below summarizes the minimum parameter groups required for both Level A and Level B implementations.

PG Number (PGN)	Description	Level A	Level B
59392	ISO Acknowledgement – Used to acknowledge the status of certain requests addressed to a specific ECU	X	X
59904	ISO Request – Request the transmission of a specific PGN, addressed or broadcast	X	X
60160	ISO Transport Protocol, Data Transfer – Used to transmit large PGNs with from 9 to 1,785 data bytes as a multiple frame message	X	
60416	ISO Transport Protocol, Connection Management – Connection setup and handshaking for data transfers using Transport Protocol	X	
60928	ISO Address Claim – Used to identify to other ECUs the address claimed by an ECU	X	X
126996	Product Information – NMEA 2000® Database Version Supported, Manufacturer’s Product Code, NMEA 2000® Certification Level, Load Equivalency Number, and other product-specific information	X	X
126208	Command/Request/Acknowledge Group Function	X	
126464	Transmit/Receive PGN List	X	
N/A	Fast Packet Protocol – Used to transmit large PGNs with from 9 to 233 bytes of data.	X	X

In addition to certification of standard self-contained products, NMEA 2000 contains provisions for third-party products. Third-party products are those products that do not entirely meet the requirements for NMEA 2000 Certification until connected to or installed on another product, usually manufactured by another manufacturer. Software packages, such as chart-plotting programs or instrumentation programs, are clear examples of third-party products. Software packages are not functional until installed on a computer or embedded processing device, and they cannot be tested for certification separately.

To distinguish themselves from self-contained NMEA 2000 Certified products, third-party products will be recognized when using one of the following key phrases:

- **“NMEA 2000 Approved”** designates products that incorporate the necessary hardware to implement NMEA 2000 and that have passed, as a minimum, the physical hardware tests in the NMEA 2000 Certification program.
- **“NMEA 2000 Certified for use with *Approved Product Name*”** designates a product that may be installed on another NMEA 2000 Approved product in order to create a fully functioning NMEA 2000 device. These devices and software packages should only be used with the approved products that are identified for the device. Operation with other unlisted approved products may not operate correctly.
- **“NMEA 2000 Approved for use with *Certified Gateway Product Name*”** designates a product that may be used in conjunction with an NMEA 2000 Certified gateway. These devices and software packages should only be used with the certified gateways that are identified for the device. Operation with other unlisted gateways may not operate correctly.

The first two products will always be used in pairs. This is because correct operation of the device is dependent upon the combined functionality and characteristics of both products. Such products may be electrically connected or may consist of software that is installed on a display or personal computer. NMEA 2000 Certified products that must be installed with an NMEA 2000 Approved product are tested under the NMEA 2000 Certification program for each product combination. The product documentation will identify the specific model and version of approved products that it has been certified with. These products should only be installed by qualified installers and technicians, who will ensure that the model and version for each product are matched to each other.

The “NMEA 2000 Approved for use with” product category is similar in nature, in that the product requires the presence of a certified gateway product to be connected to the NMEA 2000 backbone. The difference in this case is that the certified gateway contains all necessary functionality for NMEA 2000 and may be connected to the NMEA 2000 backbone for any purpose. Gateways have the unique ability to provide an interface to another product or interface standard, such as NMEA 0183, and in doing so ensure that no malfunction of the attached device can have an adverse impact on NMEA 2000 operation.

In addition to the three product categories listed above, certain products are available for performing diagnostics. These products are identified as “NMEA 2000 Approved Diagnostic Tool – Not for permanent connection to a NMEA 2000 backplane” and should only be used by qualified installers and technicians, as it is possible to disrupt normal NMEA 2000 operation when using these devices. In fact, some diagnostic tools may be designed specifically to cause certain faults in order to test the response of other devices to those faults. One example of this type of product is the NMEA 2000 Certification Tool. These products should never be left connected to an NMEA 2000 backplane for logging or any other purpose unless a qualified installer or technician is available to monitor its operation.

Products that are NMEA 2000 Certified can be found on the NMEA website; www.nmea.org

Physical Layer

The NMEA 2000 cable and connectors meeting the specifications:

- Meets USCG regulated vessel-wiring requirements
- Meets USCG regulated vessel safety concerns
- Accepted by Lloyd’s Register
- Meets UL Class 2, UL 1677 oil resistance and NEC CL2 FT 4 flame rating specifications

A very large boat builder on the East Coast that is migrating from traditional wiring on their vessels to the NMEA 2000 network using the NMEA 2000 cable and connectors has saved more than 1000 pounds of weight on each vessel. In addition, the installation labor costs have been dramatically reduced because they can finish a boat two weeks earlier. These are real cost savings. The hidden costs of training, installing the wiring correctly and other non-hidden bill of materials costs have not been calculated.

IEC 61162-3 Requirements

NMEA 2000 (IEC 61162-3) provides for the application of NMEA 2000 aboard SOLAS vessels.

IEC 61162-3 is based upon the NMEA 2000 standard. Equipment designed to this standard will have the ability to share data, including commands and status, with other compatible equipment over a single signalling channel.

Single point-of-failure conditions could exist that are capable of disrupting network operation. SOLAS applications employ redundant designs (e.g., dual networks, redundant network interface circuits) to reduce the impact of single point failures. The NMEA 2000 standard provides the fundamental tools and methods to support redundant equipment, buses, and messaging.

The term “Class 2” describes devices that have two Level A or two Level B network interface connections. Class 2 devices are intended for use on dual redundant bus systems. In addition to providing either Level A or Level B capabilities, Class 2 devices provide a means to identify messages that are received from redundant buses as being the same or different.

SOLAS Chapter V contains the requirement for Integrated Bridge Systems: “A failure of one part should not affect the functionality of other parts except for those functions directly dependent upon the

information from the defective part. Any number of redundant buses may be implemented, though typically two will satisfy the requirements above.”

IEC 61162-3 specifies two types of devices, those with one interface (Class 1) and those with two interfaces (Class 2). Redundancy may be achieved with two buses, with functions duplicated on each bus, thus providing function and bus redundancy at the system level. Duplication of function on a single bus provides function redundancy at bus level only. System redundancy requires two buses. Function redundancy may be met by having multiple Class 1 devices on each bus or Class 2 devices on both buses. Function redundancy can also be achieved with a combination of Class 1 and Class 2 devices across redundant buses.

The figures below illustrate two of many possible configurations.

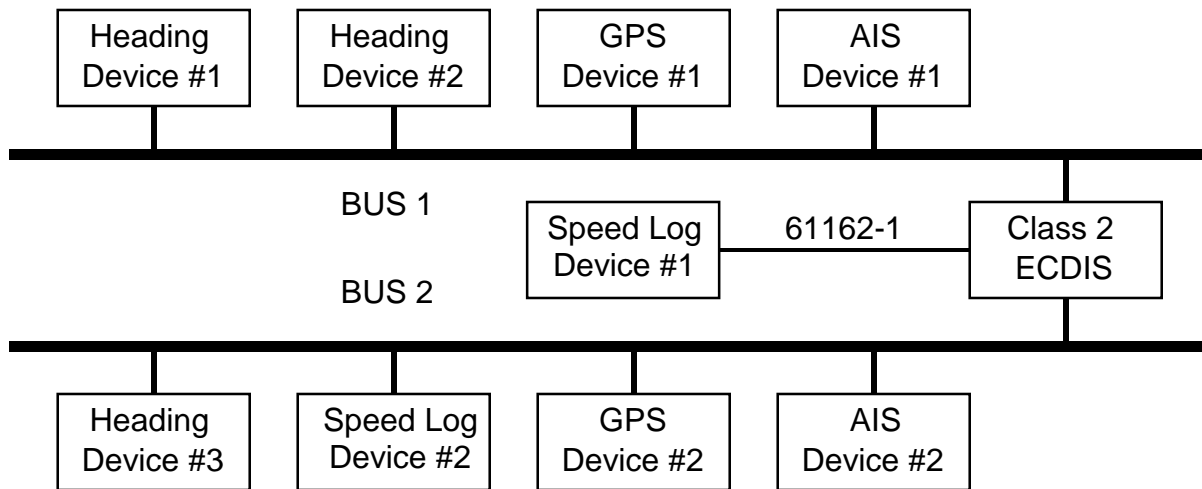

Figure 1

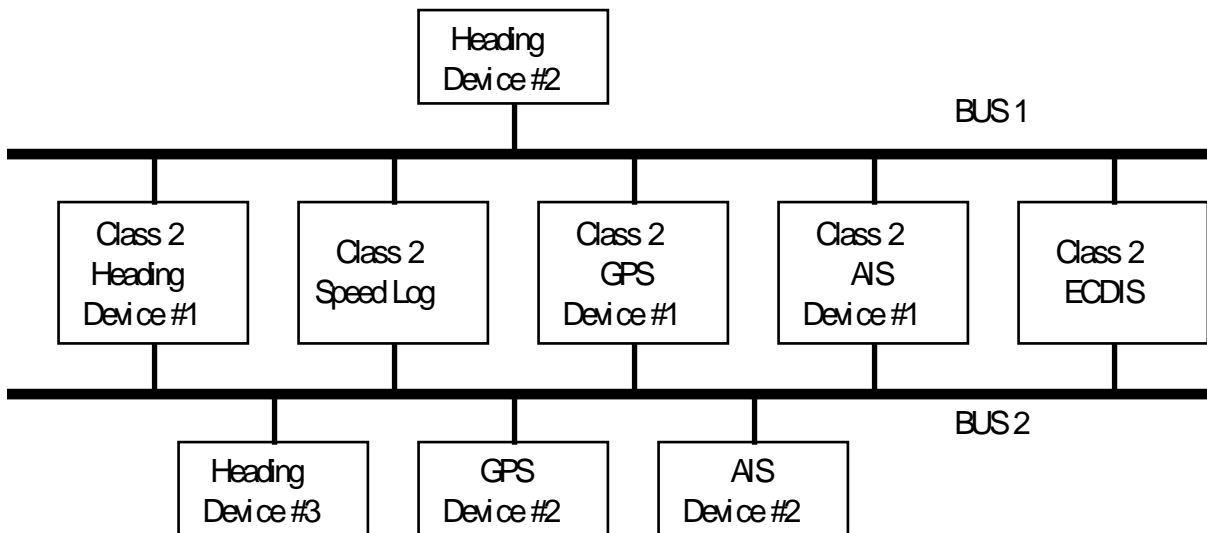

Figure 2

Future

NMEA 2000 Standards Committee and its collaborative partners, especially IEC TC80 Working 6 reacts diligently, quickly, and with technical expertise to meet emerging technologies. Some of the future abilities that are on the near horizon for NMEA 2000 (61162-3) are the following capabilities:

- Alarms and Faults – a set of tools for a suite of alarms and faults. This subcommittee has received input from the IEC INS group
- Power Generation – PGNs are being created for status and control of power generation devices, such as generators, alternators, inverters, hybrids, and shore power on ships
- Electrical Power Generation and Distribution – PGNs are being developed for the delivery of power on vessels; identifying loads, load sharing, and virtual breakers.
- 24-Volt Systems – There is a subcommittee studying the complexity of adding 24 volt systems to NMEA 2000, defining the rules and requirements.
- Common Configuration – There has been a great deal of demand that manufacturer “A” devices on the network can configure manufacturer “B” devices on the network
- Intelligent Gateways – Gateway that are “smart” and can communicate and recognize devices on both sides of the gateway and be able to transmit on the NMEA 2000 network status of the device on the other side of the gateway. Some companies today are in development of NMEA 0183 to NMEA 2000 Gateways.
- NMEA 2000 Bridges – the ability to “bridge” to other network protocols
- Galileo – collaborating with Working Group
- E-Loran – have had discussion with Working Group

References:

Robert Bosch GmbH. CAN Specification, Version 2.0, Part B (September 1991; available from <http://www.semiconductors.bosch.de/pdf/can2spec.pdf>).

Robert Boys. CAN: Controller Area Network Primer (Dearborn Group, Inc., September 2004; available from <http://www.dgtech.com/papers.php>).

National Marine Electronics Association. NMEA Installation Standards, Revision 3.0

ISO-11898 - Road Vehicles - Interchange of Digital Information - Controller Area Network (CAN) for High-speed Communications, First Edition November 1993, Amendment 1 April 1994. International Organization for Standardization, Case Postale 56, CH-1211 Genève 20, Switzerland. (Available from ANSI, 11 West 42nd Street, New York, NY 10036.)

IEC 60945, Marine Navigational Equipment - General Requirements, Third Edition, November 1996. International Electrotechnical Commission, 3, rue de Varembe, PO Box 131, 1211 Genève 20, Switzerland

ISO 11783-3. Part 3 Data Link Layer - Tractors and Machinery for Agricultural and Forestry – Serial Control and Communications Data Network. International Organization for Standardization, Case Postale 56, CH-1211 Genève 20, Switzerland. (Available from ANSI, 11 West 42nd Street, New York, NY 10036.)

ISO 11783-5. Part 5 Network Management - Tractors and Machinery for Agricultural and Forestry – Serial Control and Communications Data Network. International Organization for Standardization, Case Postale 56, CH-1211 Genève 20, Switzerland. (Available from ANSI, 11 West 42nd Street, New York, NY 10036.)